

PKG-341-MLA-CBL

System Diagram and Specifications

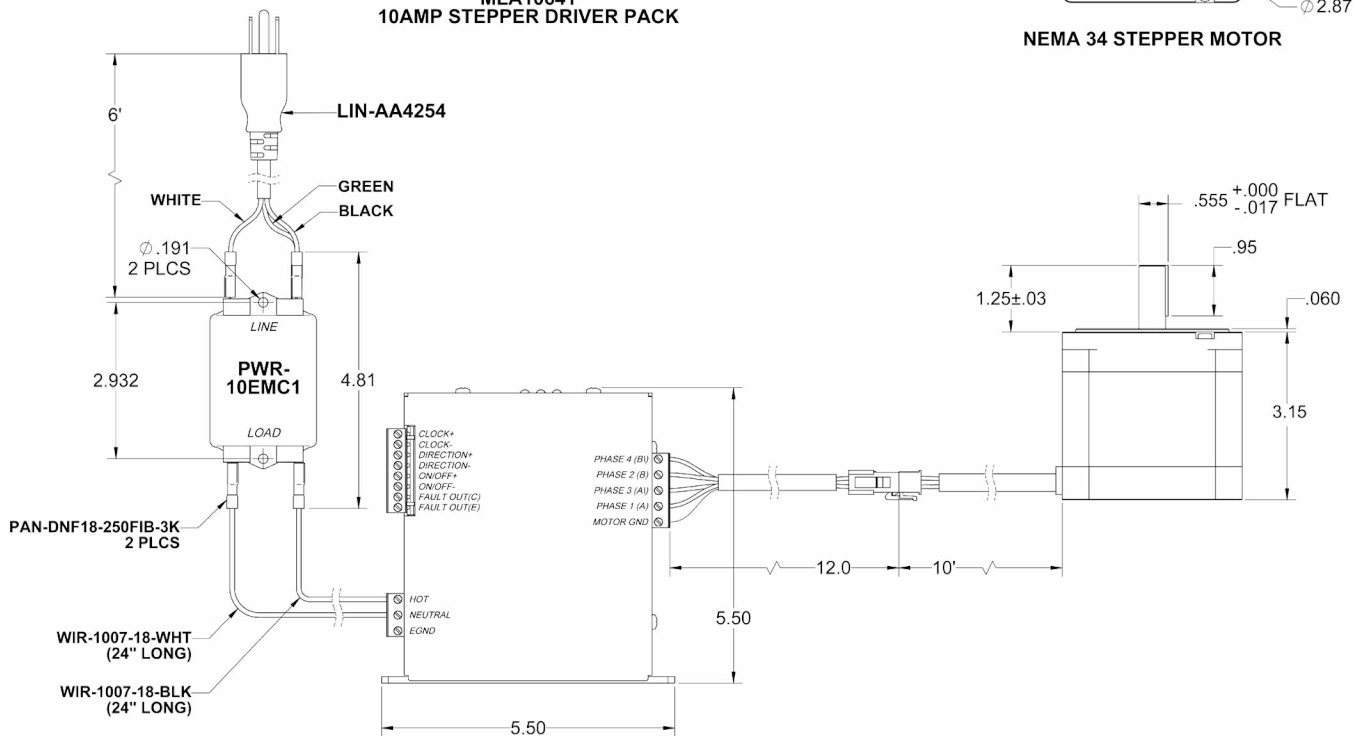

Included Components:	
34Y112S-LW8-MS	Stepper Motor
MLA10641	Stepper Driver
CBL-18AWG-04C-010-MS	Motor Cable
PWR-10EMC1	Power Filter
LIN-AA4254	Power Cord

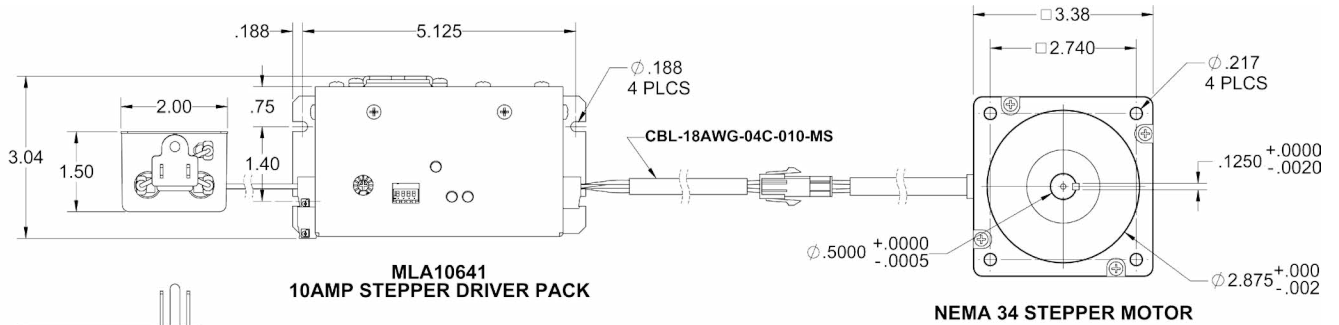
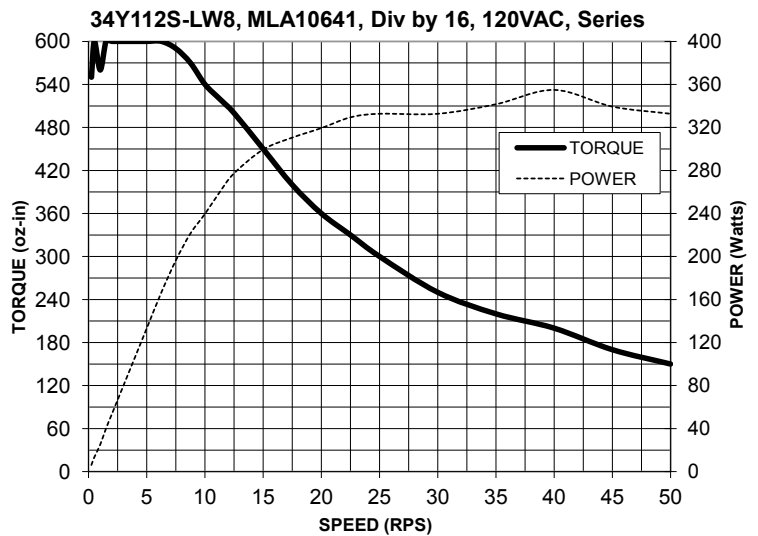

L010884

34Y112S-LW8-MS - High Torque Stepper Motor



FEATURES

- **NEMA 34 Frame Size**
- **Holding Torque - 637 oz-in**
- **1.8° Step Angle**
- **High Step Accuracy and Resolution**
- **Low Vibration and Noise**
- **CE Certified RoHS Compliant**



The 34Y112S-LW8-MS High Torque Stepper Motor offers a great value without sacrificing quality. This motor was designed to offer the highest possible torque while minimizing vibration and audible noise. It is wired in series with a Molex 4 pin Mini-Fit Jr. receptacle.

A 10 ft. 4 conductor, 18 AWG cable with mating 4 pin Mini-Fit Jr plug is included in the PKG-341-MLA-CBL stepper/motor package.

SPECIFICATIONS/DIMENSIONS

Model #	NEMA Size	Holding Torque (oz-in)	Bipolar Current (A)	Bipolar Resistance (ohms)	Bipolar Voltage (v)	Bipolar Inductance (mH)	Rotor Inertia (oz-in-sec ²)	Shaft Diameter (in)	Weight (lbs)	Length (in)
34Y112S-LW8-MS	34	637	4.3	.78	3.35	6.8	.0198	0.5	5.1	3.15

Step Angle Accuracy:	± 5% (Full Step, No Load)	Insulation Resistance:	100M Ohm Min, 500VDC
Resistance Accuracy:	± 10%	Dielectric Strength:	500VDC for 1 minute
Inductance Accuracy:	± 20%	Shaft Radial Play:	0.02" Max (1.0 lbs)
Temperature Rise:	80°C Max (2 Phases On)	End Play:	0.08" Max (1.0 lbs)
Ambient Temperature:	-20° to +50° C	Max Radial Force:	49.5 lbs (0.79" from flange)
Insulation Type:	Class B	Max Axial Force:	13.5 lbs-Force

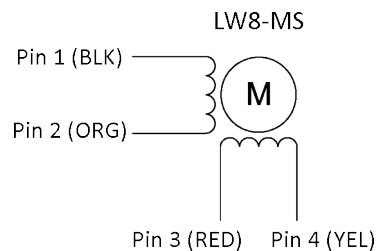

Pin #	Lead Wire Connection	Lead Wire Color
1	Phase 1 (A)	Black
2	Phase 3 (A)	Orange
3	Phase 2 (B)	Red
4	Phase 4 (B)	Yellow
	Soldered Together	White/Black & White/Orange
	Soldered Together	White/Red & White/Yellow

MLA10641 - Microstep Driver



FEATURES

- Size: 5.50”L x 2.96”W x 5.54”H
- High Torque Output
- 200 to 12,800 Steps per Revolution
- 1, 2, 5, 8, 10, 16, 32, & 64 Selectable Step Operations
- Output Current 10.0 Amps Peak
- Short-Circuit Protection
- Over-Temperature & Over-Voltage Shutdown
- No Minimum Inductance
- Optical Isolation
- Motor ON/OFF Input
- RoHS Compliant



DESCRIPTION

The MLA10641 high-performance microstepping driver has an output current capability from 2.0 Amps minimum to 10.0 Amps maximum (peak rating). The MLA10641 driver operates with an AC voltage of 90-132 Volts. The inputs are optically isolated with a minimum sourcing of 7.0 mA per input (+5VDC minimum to +24VDC maximum). The clock input is set to receive either positive or negative edge clocks with a maximum frequency of 400KHz. The MLA10641 driver offers direction control and motor current ON/OFF capabilities. The Reduce Current Enabled function automatically reduces motor current to 50% of set value after the last step is made. The driver has built-in features to indicate power on (Green LED), clocks being received (Yellow LED) and fault conditions (Red LED).

With the MLA10641, various step resolutions can be implemented by the onboard DIP switch. These divisions range from 200 steps per revolution to 12,800 steps per revolution. Protection devices have been added to this driver for phase-to-phase short-circuit, motor miswire, over-temperature and over-voltage conditions.

SPECIFICATIONS

Input Voltage (Power):	90-132VAC
Motor Bus Voltage	127-185VDC
Phase Output Current:	1.414-7.07A (RMS)
Phase Output Current:	2.0-10.0A (Peak)
Input Voltage (Inputs):	3.5-24VDC
Clock Frequency:	0-400 kHz
Fault Output Signal	Open Collector Maximum 30V/50mA
Chopping Frequency:	28-32 kHz
Operation Temperature:	0-70° C
Storage Temperature:	0-50° C

TYPICAL APPLICATION HOOK-UP

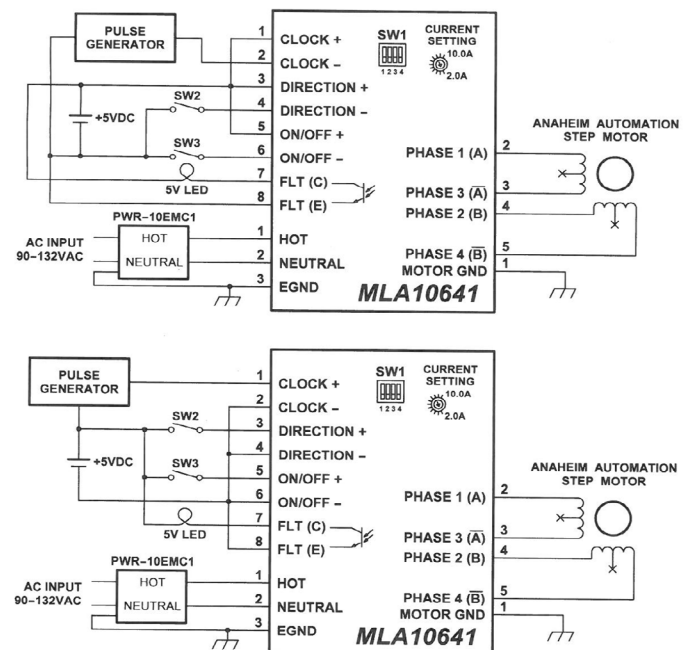

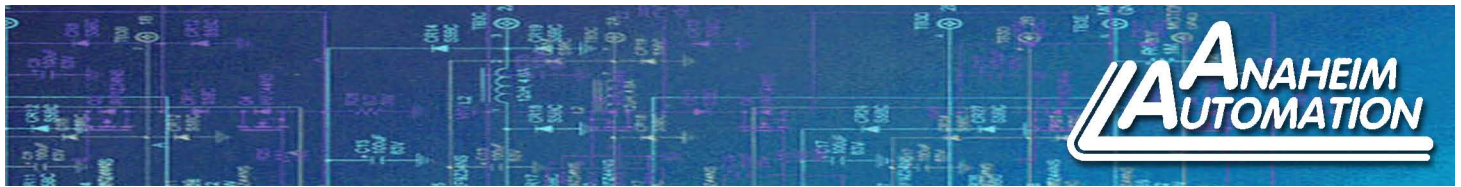

Pin Descriptions

The Inputs on the MLA10641 are optically isolated with the anode (+) and cathode (-) both brought out to the user. With no current going through the opto-diode, the input is considered high. To enable the input a minimum of 7.0 mA needs to be sourced or sinked through the opto-diode. This is done by simply placing a voltage ranging from +5 to +24VDC across the two inputs of the opto-diode. If sinking current, then all three anodes (+) should be tied together to the +voltage. If sourcing current into the inputs, all three cathodes (-) should be tied together and grounded as shown in TYPICAL APPLICATION HOOK-UP. The MLA10641 also has an optically isolated Fault Output Signal. This output has an open collector maximum voltage of 30V and can sink up to 50mA.

The Anodes (+) are pins 1, 3 and 5 and the Cathodes (-) are pins 2, 4 and 6.

Item	Pin#
Clock	1 & 2
Direction	3 & 4
On/Off	5 & 6
Fault Out	7 & 8

TB1: 8 Pin Terminal Block Description

Pin #	Description
1	Step Clock Input Anode (+): A positive going edge on this isolated input advances the motor by one increment. The size of the increment is dependent on the Microstep Select Inputs of the DIP switch.
2	Step Clock Input Cathode (-)
3	Direction Anode (+): This isolated input is used to change the direction of the motor. Physical direction also depends on the connection of the motor windings.
4	Direction Cathode (-)
5	ON/OFF Anode (+): This isolated input is used to enable and disable the output section of the driver. When HIGH (open), the outputs are enabled. However, this input does not inhibit the step clock.
6	ON/OFF Cathode (-)
7	Fault Out (C): This is the collector of the optically isolated fault output. When NO fault occurs, this output will conduct current into the emitter. Care must be taken to not pass more than 50mA of current through this transistor.
8	Fault Out (E): This is the emitter of optically isolated fault output.

Pin Descriptions for input terminal block connector (TB1)

TB2: 3 Pin AC IN Terminal Block Description

Pin #	Description
1	AC IN: Hot
2	AC IN: Neutral
3	EARTH GROUND (Must be Connected)

Pin Descriptions for input terminal block connector

TB3: 5 Pin Terminal Block Description

Pin #	Description
1	Motor Ground
2	Step Motor Phase 1 (A)
3	Step Motor Phase 3 (A)
4	Step Motor Phase 2 (B)
5	Step Motor Phase 4 (B)

Pin Descriptions for input terminal block connector

Power Supply Requirements

The MLA10641 has an input line voltage ranging from 90-132VAC. TB2 pin 1 is used as the hot terminal and is internally fused, TB2 pin 2 is used as the neutral terminal and TB2 pin 3 is the EGND terminal. The EGND terminal must be connected.

Setting the Output Current:

The output current on the MLA10641 is set by an onboard potentiometer. This potentiometer determines the per phase peak output current of the driver. The relationship between the output current and the potentiometer value is as follows:

The specified motor current of 4.3A for the 34Y112S-LW8-MS (which is the bipolar value) is multiplied by a factor of 1.4 to determine the current adjustment potentiometer value of 6.0Amps or 52%.

Peak Current	Potentiometer Setting	Peak Current	Potentiometer Setting
2.00A	0%	6.00A	52%
2.30A	10%	6.80A	60%
3.00A	20%	7.50A	70%
4.00A	30%	8.40A**	80%
4.80A	40%	9.50A**	90%
5.75A	50%	10.00A**	100%

**Although the MLA10641 has an internal fan, current settings above 8.4Amps (80%) may require additional cooling.

WARNING: Do not set the current setting above the step motor's rated current. When using a higher current setting into a motor, the motor will overheat and burn up. Should this occur, the driver will also be damaged.

Reducing Output Current

Reducing the output current is accomplished by setting switch 1 of the DIP switch to the ON position. This should occur approximately 1 second after the last positive going edge of the step clock input. The amount of current per phase in the reduction mode is approximately 50% of the set current.

Connecting the Stepper Motor:

Phases 1 and 3 of the step motor are connected between pins 2 and 3 on the motor connector (TB3). Phases 2 and 4 of the step motor are connected between pins 4 and 5 on the motor connector (TB3). The motors case should be grounded to pin 1 on the motor connector (TB3) for protection. Refer to TYPICAL APPLICATION HOOK-UP.

NOTE: The physical direction of the motor with respect to the direction input will depend on the connection of the motor windings. To reverse the direction of the motor with respect to the direction input, swap the wires on Phase 1 and Phase 3.

WARNING: Do not connect or disconnect motor wires while power is applied!

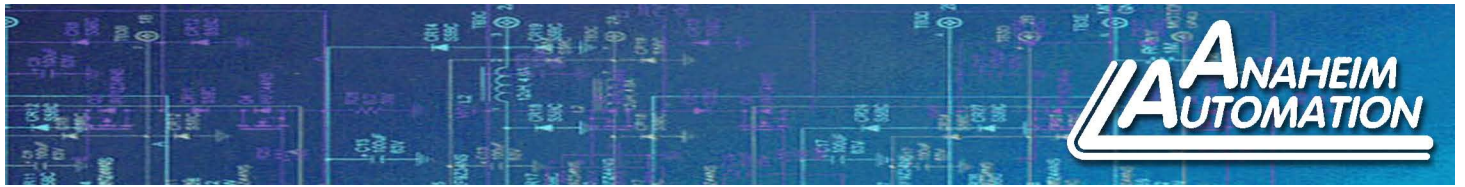

Microstepping Selection (DIP Settings)

Switches 2, 3, and 4 of the DIP switch select the microstep resolution of the driver. The table below shows the standard resolution values along with the associated positions for the select switches. The standard waveforms are sinusoidal. The steps/rev are based on a 200 step/rev motor.

Resolution	Steps/Rev	Position 1	Position 2	Position 3	Position 4	Auto Reduce Current
1	200	OFF	ON	ON	ON	Disabled
2	400	OFF	ON	ON	OFF	Disabled
5	1000	OFF	ON	OFF	ON	Disabled
8	1600	OFF	ON	OFF	OFF	Disabled
10	2000	OFF	OFF	ON	ON	Disabled
16	3200	OFF	OFF	ON	OFF	Disabled
32	6400	OFF	OFF	OFF	ON	Disabled
64	12800	OFF	OFF	OFF	OFF	Disabled
1	200	ON	ON	ON	ON	Enabled
2	400	ON	ON	ON	OFF	Enabled
5	1000	ON	ON	OFF	ON	Enabled
8	1600	ON	ON	OFF	OFF	Enabled
10	2000	ON	OFF	ON	ON	Enabled
16	3200	ON	OFF	ON	OFF	Enabled
32	6400	ON	OFF	OFF	ON	Enabled
64	12800	ON	OFF	OFF	OFF	Enabled